

## Automatic Pesticides Mixing and Spraying Robot

Jyotsna Pansare  
Department of Electrical  
Engineering  
AISSMS IOIT, Pune  
jyoppansare94@gmail.com

Tanuja Nale  
Department  
OfElectricalEngineering  
AISSMS IOIT, Pune  
tanujanale50@gmail.com

Surabhi Khonde  
Department Of Electrical  
Engineering  
AISSMS IOIT, Pune  
khondesurabhi35@gmail.com

Mrs. S.M. Shaikh  
Department of Electrical  
Engineering  
Assistant Professor  
AISSMS IOIT, Pune  
saba.mubeen@gmail.com

**Abstract:** This paper discusses the automatic pesticide mixing and spraying using microcontroller 8051. In India, 70% of the population is engaged in farming, hence most of the earning is from farming. Farmers used various types of pesticides for proper growth of the crop in large scale. And 75-80% of farmers preferred manual method for mixing and spraying those toxic chemicals which are hazardous for health. This paper provides the solution to this spraying problem; and we have tried to achieve it by design and construction of an automatic pesticide mixing and spraying robot. Its function is to mix the pesticide with water in pre-requisite amount and spray it in three directions namely forward, right and left evenly, as per the set dosage.

\*\*\*\*\*

### INTRODUCTION

Often, there is a requirement of fungicides and pesticides for optimal growing of plant and full life of plant [1]. Automating tasks within the farm will enable the avoidance of hazardous human exposure to pesticide and can increase in overall efficiency and productivity of farm. For the achievement of the desired conditions, the use of fungicides, pesticides often done by farmers [1]. Also temperature of greenhouse is high, and the level of CO<sub>2</sub> and humidity is high. Prolonged exposure to these conditions of greenhouse workers leads an hazardous and uncomfortable working environment often there are substantial risks. This project aims at providing a solution to this problem, by doing semi-automation in handling pesticides mixing and spraying operation.

### OBJECTIVES

- To develop a system which is safe, reliable and cost effective for farmers to spray pesticides automatically, this is very relevant in highly populated countries.
- Accordingly, it is an objective of the present innovation to provide a system which should be fully automated i.e. less manual interfacing.
- It should be environment friendly.
- Develop an ANSI C program and model for automated two pesticides and water (in proportion) mixing plus spraying of that mixture in three different directions.

### RELATED WORK

In the exhaustive literature survey we came across the pesticides which are often used in farming and in what quantity they are used. Also various data sheets like microcontroller 89c52, LCD 16\*2, MAX 232, diode-1N007, Relay Driver, LM-7805 (regulator IC). The actual concept

of pesticide mixing and spraying is taken from automatic mixing and spraying of colour using PLC. It has been observed that the automation of pesticide mixing and spraying system has improved the productivity, accuracy and speed of work, also more consistent performance, reduced labour cost, achieving higher productivity, main reduce human health problems and so on. In line with these works, we describe in this paper the description of automatic pesticides mixing and spraying

### BLOCK DIAGRAM

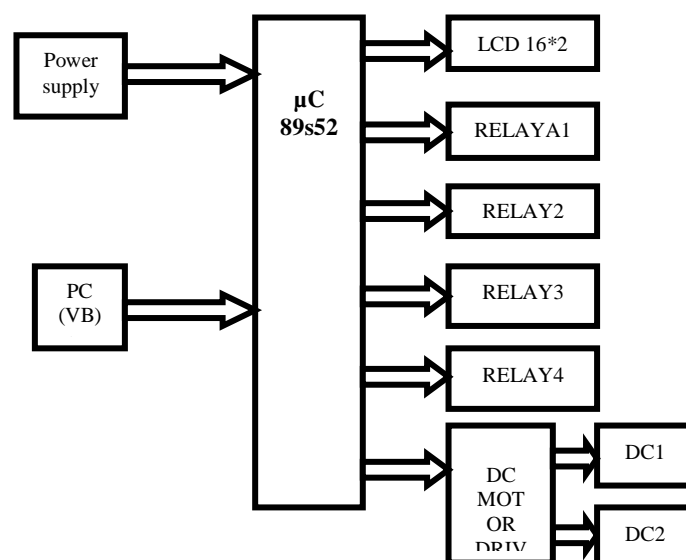

Figure 1: Basic Block Diagram

The basic block diagram, shown above depicts the arrangement of devices for the project. The power supply regulator block converts the electricity provided externally into a usable magnitude for the microcontroller and other assembly. The water motors and DC motors interfaced to the microcontroller through an relay circuit.. A display unit and interfacing unit which actually consists of LCD for displaying project name and output of different models connected to the microcontroller can be connected externally to the microcontroller A personal computer can be interfaced with the microcontroller for programming and for giving actual command to model.

*Abbreviations and Acronyms*

- PIV(Particle Image Velocimetry)
- TUF(Transformer utilization factor)
- MCLR(Master Clear Pin Reset)

**V.COMONENTS**

*89c52-Microcontroller*

The 89c52 is a microcontroller designed by Atmel.The AT89S52 is a low-power; high-performance CMOS 8-bit microcontroller with 8K bytes of in-system programmable Flash memory.This is a powerful and a power efficient device which can be used for a variety of applications. It has the ability to execute most of its instructions in one cycle, therefore improving its speed of operation. This microcontroller is perfect for implementing C-programmes as the Atmel Company provides the best compiler and application support.

*Power Supply*

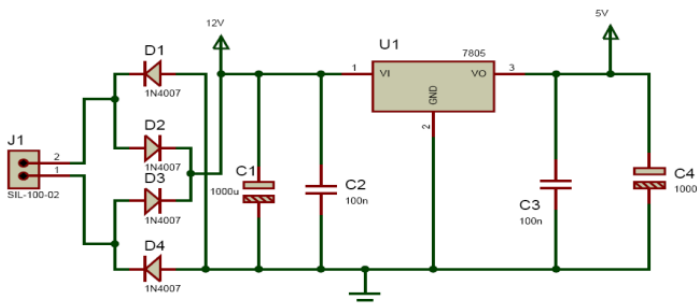

Figure2:Power Supply Design

The main part of the system is power supply.The microcontroller functions on a 5 volt supply, while the entire unit requires 24 volts to function. The 5 volt supply to the microcontroller is provided by the 7805 IC which is a voltage regulator. When we have to design any system, we must design power supply first. There are two basic steps in designing of power supply:

- 1) Determination of the total current that system takes from the supply.
- 2) Determination of the voltage rating required by the different components.

When 230v AC supply is applied to the terminals, the bridge rectifier rectifies that voltage and converts it into the DC voltage. Still some AC components are present in that voltage, so the capacitor filter produces an unregulated DC voltage. That voltage is applied at the I/P of 7805 and constant supply required to the total circuit is maintained by IC 7805 which is 5V. Also 12V DC supply is required at motor terminals which are maintained by another power supply.

*LIQUID CRYSTAL DISPLAY:*

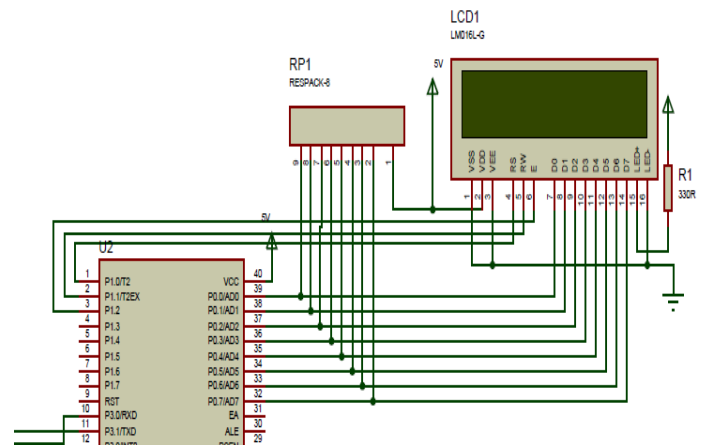

Figure3: LCD interfacing with micrcontroller

16x2 LCD is used i.e. it has 16 columns and 2 rows.

LCD has two main functions:

- 1) LCD is used to visualize the output of the application. So, we can write 16 characters in each line. Total 32 characters can be displayed on 16x2 LCD.
- 2) LCD can also be used to check the output of different modules interfaced with the microcontroller. Thus LCD plays a very important role in a project to see the output and to debug the system module wise in case of system failure in order to rectify the problem [6].

•LCD has 2 power sources:

- 1) VCC and GND- Pin no's 1 and 2 of LCD. They are used to drive the LCD. Normally current consumption is 3 mA.
- 2) VCC and GND- Pin no's 15 and 16 of LCD. They are used to drive and adjust the backlight of LCD.100 mA is current consumption.[6]

•LCD has 8 or 4 data lines and 3 control lines

Pin no. 7 to pin 14 of LCD are the 8 data lines of LCD which are connected to the port 0 of microcontroller 89s52 i.e.P0.0 – P0.7.

The control lines of LCD are RS, R/W, and E. These 3 lines are connected to the port 1 of the 89S52 microcontroller. i.e. to the P 1.0 , P 1.1 , P 1.2 respectively. The RS pin of LCD is for selecting the data or the code register. The R/W is for choosing between reading and writing on LCD. E is for enabling or disabling the LCD.

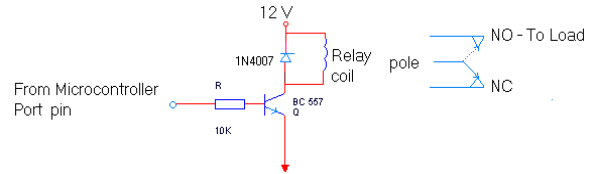

Figure 5: Internal relay driver circuit.[6]

**DC Motor**

DC motor is a simple, robust electromechanical device which converts an electrical input into a physical, rotary output. The motor used at the output side is a 30 R.P.M,12 Volt, plastic geared D.C. Motor.2 DC motors are used to drive the buggy in various directions.

Two water motors(water pumps) are used for lifting the pesticides from container.

One water pump is used for lifting the water from water container.

And the last water pump is used for lifting the mixed content of water and pesticides from the fourth container.

To drive a dc motor, we need a dc motor driver. This is L293D. At a time two DC motors are driven by using this DC motor drive. But, in our system we have to change the direction of rotation of wheels which is done by the changing the direction of the DC motors and at that time back EMF is generated. To protect the dc motor from a back EMF generated while changing the direction of rotation DC motor driver is used, it has an internal protection suit.

**Circuit Diagram:**

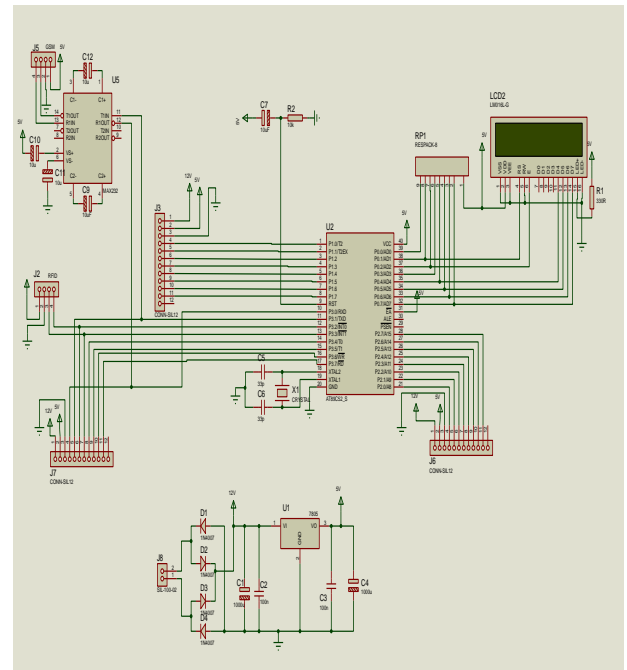

Figure6: Circuit diagram

**Relay and Relay Driver Circuit**

Relay is an electromagnetic switch which has the property to switch one circuit to another circuit. It consists of 1 common (COM) terminal, 1 normally closed (NC) terminal, coil and 1 normally open (NO) terminal.

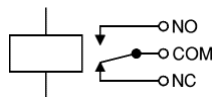

Figure4: Symbol of a relay for circuit [6]

Connections of the relay switch are generally labelled as-COM, NC and NO:

- COM: Common is always connecting to this terminal and it is the moving part in the switch.
- NC: Normally Closed terminal, COM terminal is connected to this when the relay coil is OFF.
- NO: Normally Open terminal, COM terminal is connected to this when the relay coil is ON.

Relays allow the switching of one circuit to another circuit.

**RESET CIRCUIT:**

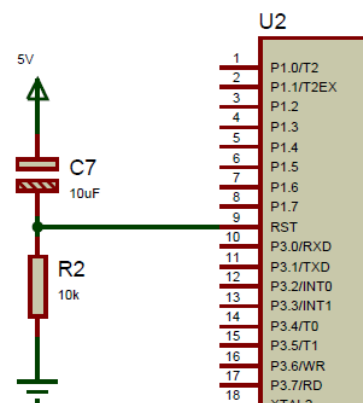

Figure7: Connections of Reset

Above circuit shows the connection of an RC circuit to the RESET i.e. pin no 9 of controller .The microcontroller 89S52 has an active high reset pin, due to that we connect an RC circuit. As shown in the fig the capacitor is initially at 5v during supply ON and capacitor charges from the supply

through a 10 µf capacitor in series with it. When we have to put the microcontroller into a 'known' condition, reset is used.

That practically means under certain undesirable conditions microcontroller can behave rather inaccurately in that situation and to continue its proper functioning it has to be reset. It means all registers would be placed in a starting position i.e. at their initial location. Another function of reset is when microcontroller doesn't behave the way we want it to, it can also be used when trying out a device as an interrupt in program execution, or to get a microcontroller ready when loading a program.

### CRYSTAL CIRCUIT

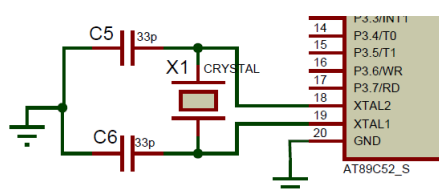

Figure 8: Connection of Crystal Circuit

Microcontroller 89c52 has two Pins: OSC1 & OSC2 for connecting a resonant network to form oscillator. Generally the quartz crystal and capacitors are used. The frequency of crystal is the basic internal clock frequency of the microcontroller. Here we are connecting two ceramic capacitors which are basically used for filtering purpose. In other words to give a pure square wave to the microcontroller we are connecting the two capacitors. Frequency is 11.0592MHz

### VI. MICROCONTROLLER 89C52 SPECIFICATIONS

Features [6]

- Compatible with MCS-51® Products
- 8K Bytes of In-System Programmable (ISP) Flash Memory – Endurance: 1000 Write/Erase Cycles
- 4.0V to 5.5V Operating Range
- Its operation is Fully Static : 0 Hz to 33 MHz
- Three-level Program Memory Lock
- 256 x 8-bit Internal RAM
- 32 Programmable I/O Lines
- Three 16-bit Timer/Counters
- Eight Interrupt Sources
- Full Duplex UART Serial Channel
- Low-power Idle and Power-down Modes
- It had facility to Interrupt Recovery from Power-down Mode
- Watchdog Timer
- Dual Data Pointer

- Power-off Flag
- Fast Programming Time
- Flexible ISP Programming (Byte and Page Mode)
- LCD-16\*2-
  - a) LAMPEX
  - b) 16\*2, BACKLIT FACILITY,
  - c) 100mAmp CONSUMPTION

### VII. SEQUENCE OF OPERATION OF PESTICIDE MIXING AND SPRAYING ROBOT:

- Pesticides 1 and 2 are filled in their two containers; also water is filled in the 3<sup>rd</sup> container.
- When supply is given circuit is ON, project name is displayed on LCD.
- Microcontroller is automatically reset through reset circuit.
- Command is given from PC for selecting the proper combination in 40/60 ratio i.e. Amount of pesticide should not exceed 40% and amount of water should be 60% and after that MIX command given.
- When these two actions are done water pumps start and mixing of two pesticides and water is done in 4<sup>th</sup> container.
- We can also mix only one of the pesticide and water by doing the same action.
- After the mixing operation connector is removed and container unit is separated from the moving unit.
- On our PC screen, two or more commands are available i.e.
  - 1) PATH SELECTION
  - 2) START
  - 3) STOP (MANUAL)
- There are three paths available
  - 1. Forward
  - 2. Forward and right
  - 3. Forward and left
- After selecting the path from PATH SELECTION, START command is given to the controller which moves the buggy in given direction with spraying action simultaneously.
- When we give STOP command from PC, buggy stops at that place and simultaneously spraying action also stops.

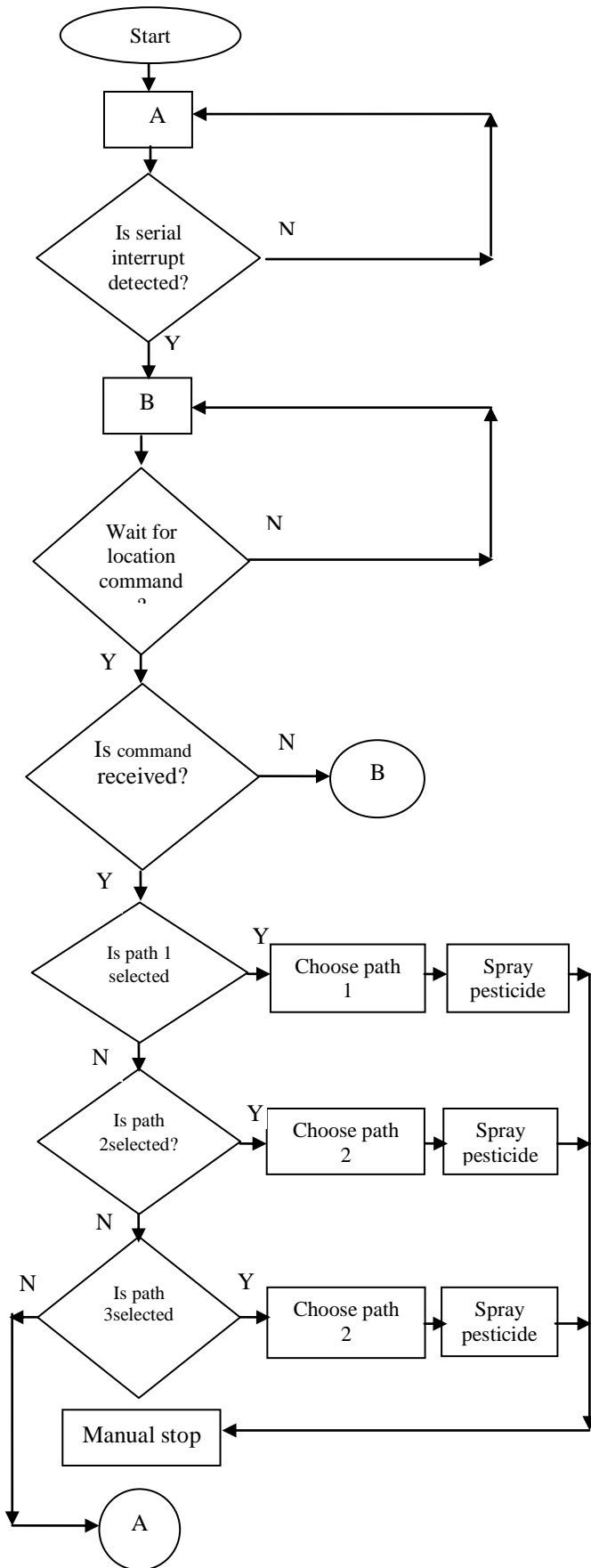

Figure 9: Flowchart of Pesticide Mixing

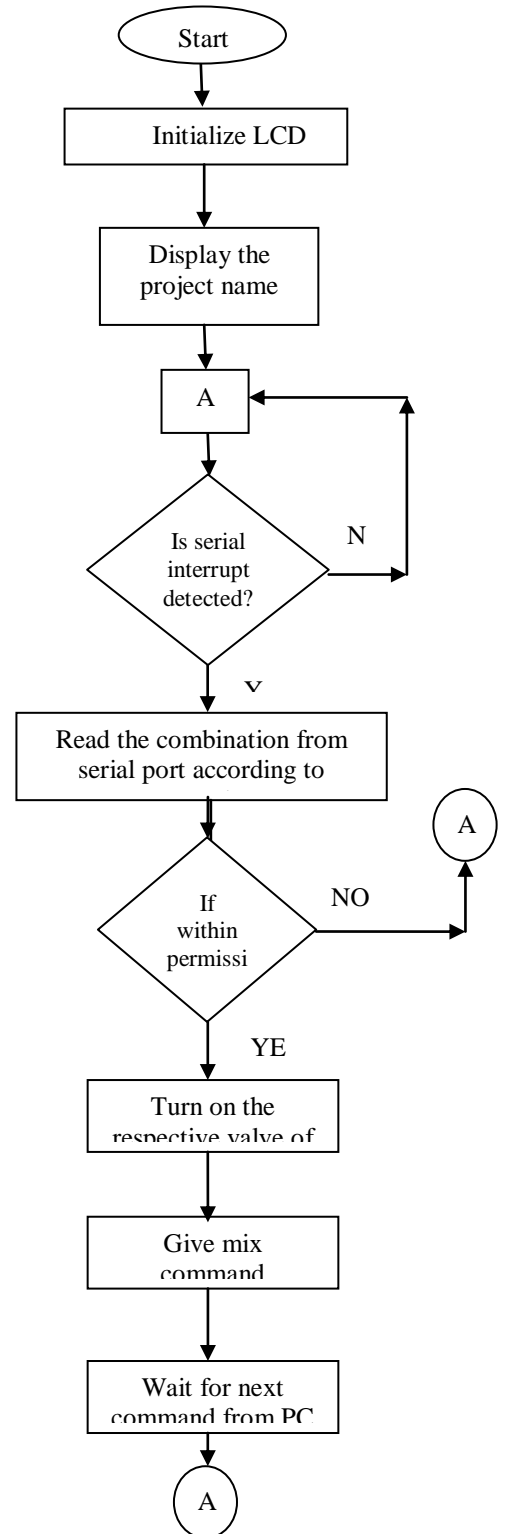

Figure 10: Flowchart of Pesticide Spraying

### VIII. PCB LAYOUT

Layout basically means placing or arranging things in a specific order on the PCB. This placement is made such that the interconnection lengths are optimal. At the same time, it also aims at providing accessibility to the components for insertion testing and repair.

When we have to start final artwork, PCB is the main starting point, it should reflect the concept of final model

- [5] Riley B., Siemsen-Newman L., (2003) "Health Hazards Posed to Pesticide Applicators", Northwest Coalition For Alternatives to Pesticides, pp. 17-24.
- [6] DATA SHEETS of 89c52, RELAY DRIVER BC-547, LCD 16\*2, LM 7805
- [7] "Color making and mixing process using PLC", S.T. Sanamdikar and Vartak C

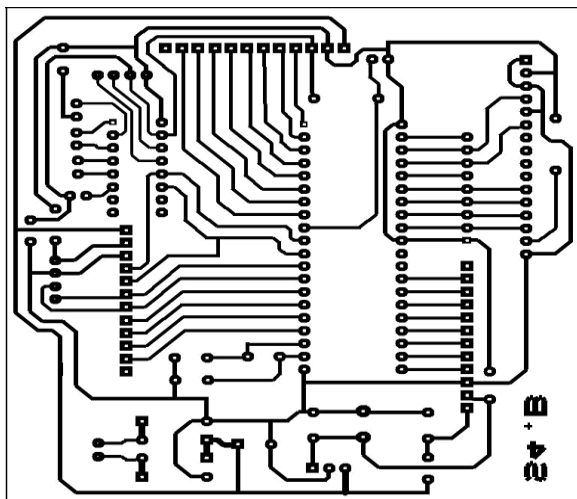

Figure 11: PCB layout of circuit

### IX. CONCLUSION

In this paper, a system has been successfully designed that will prove very useful in the field 'GREENHOUSE farming'. Based on testing and working of the system we conclude that the system designed will provide facility for mixing of different pesticides and water also spraying of that mixture on crops, which otherwise would have been difficult to do manually and main disadvantage of manual operation is it is health hazardous. We learnt to design the model based on controller programming. The system can be operated semi-automatically

### X. REFERENCES

- [1] "Autonomous Pesticide Spraying Robot for use in a Greenhouse", Philip J. Sammons, Tomonari Furukawa and Andrew Bulgin ARC Centre of Excellence for Autonomous Systems School of Mechanical and Manufacturing Engineering The University of New South Wales, Australia [t.furukawa@unsw.edu.au](mailto:t.furukawa@unsw.edu.au) September 9, 2005
- [2] Badgery-Parker, J. (1999), Agnote DPI/249, Edition 1, pp. 1-2.
- [3] Van Henten, E.J., Hemming J., Van Tuijl, B.A.J., Kornet, J.G., Meuleman, J., Bontsema J., & Van Os,
- [4] E.A. (2002), "An Autonomous Robot For harvesting Cucumbers in Greenhouses", Autonomous Robots, Vol 13, pp. 241-258.